

ROOF DECKS

A to Z

Part VII: Cast-In-Place Structural Concrete

By L.D. Hogan, RRC, FRCI, PE, and Rob Kennerly, PE

Abstract: *This is the seventh in a series of articles examining various deck types. Among the numerous considerations when selecting a roof system, the type of decking is among the most important. With the variety of decks to be encountered (both new and old), it is incumbent upon roofing experts to be the authority on these matters. This article will explore features of cast-in-place structural concrete decks. Aspects of placement techniques and mix proportioning are not examined in this text.*

Confusion abounds regarding this seemingly straightforward type of roof deck. To simply refer to it as a “concrete deck” can mean any number of things, as there are numerous types of concrete, components, and assemblies that are commonly used in the construction of roof decks. Cast-in-place concrete deck systems (also referred to as job-cast; *Figure 1*) are explored here, along with a definition of differences between insulating and structural concrete.

To understand how a “lightweight” deck (seen in some approval-guide directories) functions, some clarification may be in order. If a roof deck is termed merely “lightweight,” that begs the question: Does this mean lightweight insulating concrete, or does it mean lightweight structural concrete? Lightweight insulating concrete is made using manufactured lightweight aggregates such as perlite, vermiculite, or polystyrene beads that provide insulating properties. Depending upon the design mix,

the dry density of the insulating concrete can vary from 20 to 40 pounds per cubic foot and attain a compressive strength of 125 to 500 pounds per square inch.

Another type of lightweight insulating concrete is commonly referred to as “cellular” concrete. This concrete is produced by mixing Portland cement and water with an air-entraining agent or pregenerated foam. As the Portland cement and water slurry are combined with the preformed foam, the foam bubbles become coated with

the cement paste. As the mix hardens, the bubbles remain and produce concrete with air cells; thus, the name “cellular” concrete. The dry density of these mixes varies from 24 to 32 pounds per cubic foot, yet insulating concrete is not a structural component. This configuration of roof deck was explored in an earlier installment of this series.

There are two general types of structural concrete: “normal-weight” and “lightweight.” Structural concrete can be mixed from any number of designs to yield desired physical



Figure 1 – The network of internal reinforcing steel for a project that will soon receive the concrete pour. Note the temporary forms that will later be stripped from below.



Figure 2 – Cast-in-place concrete may be configured to many different profiles. Here, the designer envisioned a hyperbolic paraboloid saddle.

Figure 3 – Folded plate concrete is a less-common variety, relegated more often to older structures.

and performance properties. The terminology on a set of construction drawings that refers to “concrete” typically implies that the concrete is normal-weight.

Normal-weight structural concrete (NWSC) is made with natural stone or crushed gravel (complying with ASTM C33) that is mixed with Portland cement, sand, water, and various chemical admixtures used to enhance physical properties of the mix. Dry density of normal-weight concrete typically ranges from 145 to 155 pounds per cubic foot, and typical compressive strengths range from 3,000 to 6,000 pounds per square inch. For reference, there is nothing at all lightweight about this material. As a matter of fact, it’s the heaviest roof deck that comes to mind.

Lightweight structural concrete (LWSC) is similar to NWSC, except the former is approximately two-thirds the weight of the latter. LWSC is made with ingredients similar to normal-weight concrete except that lightweight aggregates, complying with ASTM C330, are utilized instead. These lightweight aggregates are made from natural-occurring products such as shale, clay, and slate. These products are crushed and some products are heated to high temperatures, causing a small amount of water that is naturally embedded in the aggregate to turn to steam, and causing the particles to expand in volume. The expanded particles are lighter than crushed gravel, and when used in a concrete mix, result in a density of 85 to 120 pounds per cubic foot; compressive strength values are comparable to those of NWSC.



The types of embedded steel reinforcing can vary, depending upon structural requirements for the particular project. Job-cast concrete typically utilizes one of two types of steel reinforcing that is embedded into the concrete at the time the concrete is cast at the project site. These are usually mild-strength deformed steel bars, or instead, high-strength steel strands (called tendons) for when post-tensioning is to be carried out. When tendons are utilized, the steel strands are typically sheathed in steel or plastic tubes to prevent the wet concrete from bonding to them. Once the concrete has cured to a certain compressive strength, the tendons are then pulled (tensioned) with a hydraulic jack, and the tension force is permanently locked with anchors at the tendon ends. This method provides an effective means for concrete structures to carry

heavier loads than when the structures are reinforced with mild-strength bars. The configuration is different enough from ordinary cast-in-place decks that it will be explored in a separate installment of this series.

Job-cast structural concrete decks can be cast to a dead-flat profile. Sometimes, this flat profile is used in anticipation of a future vertical expansion of a building, whereby the former roof deck becomes a new floor level. Alternatively, structural concrete roof decks can be cast and finished with a top surface that is sloped to drains.

Job-cast concrete can be cast into various shapes in order to meet requirements of the designer and can include unusual shapes such as hyperbolic paraboloids (known also as saddles; *Figure 2*) and folded plates (*Figure 3*). The structural concrete can be cast integrally with penthouse curbs,



Figure 4 – Here the concrete is cast monolithically with the column capitals. This arrangement was common in multistory buildings in decades past.

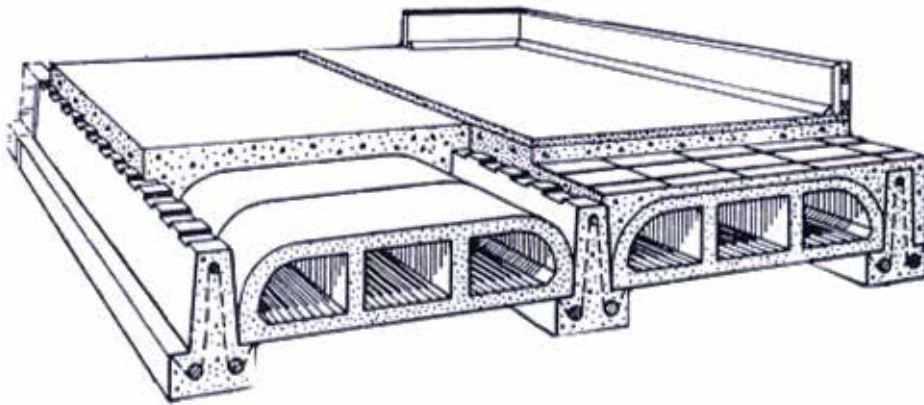

Figure 5 – Concrete is often found in a “composite” arrangement; here, concrete beams (containing the reinforcing steel) and cinder tiles are the permanent form for a concrete topping.



Figure 6 – Fabric sheet reinforced with steel wire grid over open-web bar joists.

parapet walls, and even support columns (Figure 4). The final shape of the concrete is limited by the structural requirements of the section and by the practicality of building and disassembling temporary forms that are used to hold the wet concrete.

There is a considerable variety in the types of forms that are encountered in job-cast structural concrete. Accordingly, the underside appearance of the deck can reveal how to properly identify and characterize it. While most forming systems today are temporary, it was common practice in older buildings to utilize forms that remained or partially remained in place after the concrete was cast and cured. Stay-in-place forming systems in older buildings were economical because they saved the costs of stripping and cleaning the forms after the concrete cured. Forming systems commonly utilized for job-cast concrete roof decks can include:

- Proprietary flat and modular panel systems (i.e., Symons forms, etc.)
- Fiberglass or metal “pan” forms to support one-way and two-way structural concrete decks
- Hollow tiles serving as the permanent form (Figure 5). This deck is a “composite” arrangement, usually placed on concrete beams that contain the reinforcing steel.
- Fabric sheet or layers of building felt reinforced with steel wire grid placed over open-web steel bar joists (Figure 6)

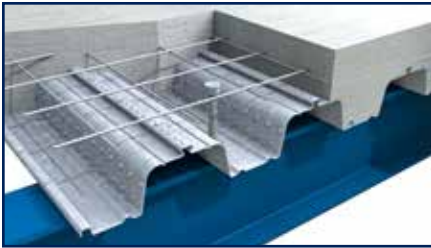

Figure 7 – Composite cold-formed steel decking as the permanent form. In this arrangement, deformations in the ribs enhance bond between concrete and the steel form. The concrete may also be reinforced with bars and/or welded wire fabric and possibly Nelson studs. This assembly should never be confused with ordinary fluted steel decking.



Figure 8 – Expanded wire lath was a common permanent form in decades past.

- Composite cold-formed steel decking as the permanent form. In this arrangement, deformations in the ribs enhance bond between the concrete to the steel form. The cast-in-place concrete may also be reinforced with bars and/or welded wire fabric and possibly Nelson studs such as with floor mezzanines (Figure 7). This assembly should never be confused with ordinary fluted steel decking.



Figure 9 – Cinder concrete atop expanded wire lath (image courtesy of Donald Kilpatrick).

- Expanded wire lath used to support a concrete slab (Figure 8). These often have cinder concrete on top (Figure 9).
- Structural clay tile (also called “book tile”), situated between concrete beams and columns, supports concrete roof decks (Figure 10). In such an arrangement, the concrete topping course may be quite thin, covering little more than the top of the tile units (Hogan, 2011).

At the risk of complicating matters, a roof deck might be constructed as a composite system having insulating concrete placed on top of structural concrete. This is often done to achieve insulation in the roof and for creating slope contours for drainage. In this instance, core sampling into the roof from above may reveal different materials than interior observations reveal from below. The investigating consultant should

always review any available construction documents and then confirm conditions by visual observations and coring when practical.

When it is time to place the roof over a concrete deck, there is frequent concern about the amount of latent moisture in recently placed concrete or regarding a deck that has been subjected to water infiltration from a failed roof covering. This con-

cern is usually associated with floor slabs that are to receive a coating or final covering; however, there is sometimes equivalent concern when adhesives (especially hot bitumen) are to be used in a roof assembly. There are four recognized methods for determining moisture in concrete. The tests are classified as qualitative or quantitative, with qualitative tests providing a general indication of moisture and quantitative tests providing a numerical result (Schnell, 2014). These are:

1. **Plastic sheet test** (ASTM D4263, *Test Method for*

Indicating Moisture Content in Concrete by the Plastic Sheet Method). This is a qualitative test method that relies on a dew point and enough moisture in the concrete slab to condense at the surface temperature of the concrete. This method is



Figure 10 – Concrete roof decks may be poured over structural clay tile (also called “book tile”) situated between concrete beams and columns.

- being dismissed as a poor indicator because of sealing difficulties at the sheet edges (Schwetz, 2014).
2. **Electronic instruments:** Electrical resistance test (moisture meter), electrical impedance test (comparative measures of moisture in slabs),

- nuclear moisture gauge (comparative measures of moisture in slabs), and nuclear magnetic resonance
3. **Moisture vapor emission rate (MVER):** Calcium chloride test (ASTM F1869, *Standard Test Method for Measuring Vapor Emission Rate of Concrete Subfloor Using Anhydrous Calcium Chloride*). This is a quantitative test method most commonly recognized in the U.S. for the determination of moisture conditions in concrete slabs. The test method suffers from several serious deficiencies, and users should interpret test results with caution.
4. **Relative humidity measurement** (ASTM F2170, *Standard Test Method for Determining Relative Humidity in Concrete Floor Slabs Using In-Situ Probes*). This is a quantitative test method that uses electronic probes to measure moisture in concrete.



Figure 11 – Hot bitumen was—and continues to be—a plausible adhesive for insulation on concrete decks. This image, however, depicts poor (virtually nonexistent) adhesion of a roof that was installed over an old vapor retarder surface following tear-off.

Direct-to-deck adhesion of insulation with mopping asphalt historically has greater problems than that of excess moisture in the deck. Asphalt was—and continues to be—a plausible adhesive for insulation on concrete decks. When components are adequately bonded, astounding uplift values can be achieved; however, the critical

notion is the time window for getting the boards situated and properly “stepped-in.” Unfortunately, the hot bitumen is often allowed to chill (from “long-mopping”) or does not gain full contact under construction traffic to develop the adhesion needed. Poor embedment of insulation has often been observed during exploratory coring of roofs. *Figure 11* depicts virtually nonexistent adhesion of insulation that was adhered to an old vapor retarder following tear-off. In reroofing scenarios, there is often a temptation to tear-off down to the old vapor barrier. In that event, however, the entire new assembly (if adhered) is dependent on the bond between the concrete deck and the vapor barrier; that surface may very well be the “limiting element” in



Figure 12 – Regardless of what the static dew point analysis may suggest, a vapor barrier should be reconsidered in new construction or where an existing deck has been wet for extended periods.

19 years of vegetated roof experience... brought to life in one app.



American Hydrotech introduces the Garden Roof® Planning Guide iPad® app – a first-of-its-kind digital brochure that helps design professionals take a vegetated roof from initial concept to completion.

Packed with photography, technical information and videos, design professionals can explore assembly options and components, growing media and vegetation, and learn about topics such as design considerations, economic and sustainable benefits, installation and maintenance, and much more.



Download your copy today at
hydrotechusa.com/GRPG



American Hydrotech, Inc.
303 East Ohio | Chicago, IL 60611 | 800.877.6125 | www.hydrotechusa.com

© 2015 Garden Roof is a registered trademark of American Hydrotech, Inc.

overall uplift resistance. Test it, carefully evaluate it, or tear it off if there is any question about this interface.

Scarifying an old concrete deck surface is nice but seldom practical in reroofing. Such work is tedious, and having the covering off an occupied building for an extended time is risky. If asphalt is to be used as the adhesive, quick-dry bituminous primer (i.e., ASTM D41) is highly recommended to adhere insulation boards and ply sheets to bare concrete, be it old, scarified, or freshly placed.

Structural concrete is capable of very good fastener engagement. On such decks, fastener withdrawal testing will undoubtedly result in extraordinary values—sometimes well beyond 2,000 pounds. However, just a few hours at the business end of a rotary hammer will have the operator pondering alternative ways to anchor the insulation. There is also the risk of encountering steel-reinforcing tendons when mechanical fastening is implemented. Modern low-rise foam adhesives have met this need and are capable of yielding equivalent wind ratings for modern roof assemblies.

SUMMARY REMARKS

The air impedance benefit of monolithic cast-in-place concrete is recognized, even by loss-prevention agencies that do not test or evaluate concrete decks. When poured integrally with parapet walls and penthouse curbs, the time rate of air diffusion through such a deck is quite low. Accordingly, loosely laid roofs (ballasted with stone or pavers where permitted by code) are a good

selection. Inverted roofing tiles and even valve-equalized systems marry well on cast-in-place concrete decks.

Finally, of recent interest and concern are 1) unexplained moisture gain, 2) the loss of insulation facer bond, and 3) development of biological colonies in some materials installed over concrete decks (Figure 12). Even when no vapor retarder was necessary (by psychrometric determination), sensitive organic materials have absorbed moisture, causing insulation-facer distress (both cohesive and adhesive) and development of mold (Capolino, 2014). Cranking up interior heat shortly following concrete placement can aggravate these behaviors. Regardless of what the static dew point analysis may suggest, a vapor barrier should be reconsidered in new construction or where an existing deck has been wet for extended periods. 

REFERENCES

- Remo Capolino, "Entrapped Moisture ... But This Is a LEED Gold Building," *Interface*, July 2014, pp. 34-38.
- Lyle Hogan, Don Kilpatrick, and Richard Koziol, "Roof Decks A to Z; Part 3: Structural Clay Tile and Plywood," *Interface*, November 2011, pp. 5-10.
- Don Schnell, "Reducing the Moisture Content in Poured Concrete Slabs," *Durability + Design*, May 2014, p. 18.
- Joe Schwetz, "Risks of Roofing Over Concrete Decks," *Interface*, July 2014, pp. 20-32.



Lyle D. Hogan,
PE, RRC

He has designed and administered roofing projects in half of the U.S. using a variety of systems. Hogan has received RCI's Lifetime Achievement Award, its William C. Correll Award, and its Horowitz Award.



Robert G. Kennerly
Jr., PE

Robert G. Kennerly Jr., PE, is founder and owner of Engineered Concepts, a structural engineering and building solutions firm located in Greensboro, North Carolina. Kennerly has more than 35 years of experience in the design of building structures and in the investigation and remediation of problems with building enclosures. He is a registered professional engineer in 12 states across the Southeast and Mid-Atlantic.

Lyle Hogan is owner and principal engineer of Fincastle Engineering, Inc., Greensboro, North Carolina. He is a registered engineer in five states, a Registered Roof Consultant, a Fellow of RCI, and an ICC structural masonry inspector.

Robert G. Kennerly Jr., PE, is founder and owner of Engineered Concepts, a structural engineering and building solutions firm located in Greensboro, North Carolina. Kennerly has more than 35 years of experience in the design of building structures and in the investigation and remediation of problems with building enclosures. He is a registered professional engineer in 12 states across the Southeast and Mid-Atlantic.

CALL FOR ABSTRACTS

RCI is seeking abstracts for consideration for the 2015 Building Envelope Technology Symposium. The event will be held November 9-10, 2015, at the Gaylord Opryland Resort and Convention Center in Nashville, Tennessee. The symposium abstract submittal deadline is April 27, 2015. More information may be found at rci-online.org/symposium.html.

RCI is also seeking abstracts for the 31st RCI International Convention and Trade Show to be held March 10-15, 2016, at the Rosen Shingle Creek Resort in Orlando, Florida. Submittal deadline for these abstracts is May 18, 2015. For more information, visit rci-online.org/international-convention.html.



Scan the QR code for more information online.